

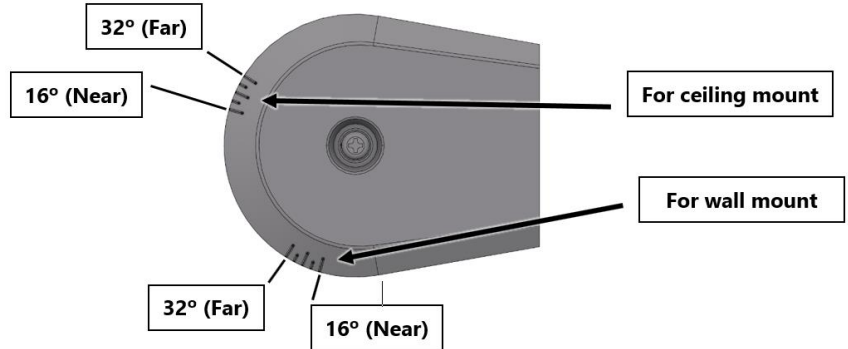

QuickStart Guide with Remote Control

Mounting

1. Remove the two hinge screws from the side of the unit to remove the sensor from the mounting bracket.
2. Install the mounting bracket at a height between 11.5-21 ft (3.5-6.5 m) from the ground.
3. Reattach the sensor to the mounting bracket and adjust the sensor to the desired angle (16-32°), then tighten the hinge screws to lock the sensor in place.



Wiring Connections

1. Connect power (12-24 VDC/AC) to the **Red** and **Black** wires. They are not polarity sensitive.
2. Wire the OWL's detection relays into the door/gate operator.
Infrared presence detection - **White/Green**
Microwave vehicle motion detection - **Yellow/Blue**

Programming with Remote Control

1. **The OWL-RC remote control is required for programming the OWL.**
2. If the sensor has a 4-digit security code, press the **I** key, enter the security code, and press the **#** key.
3. If the sensor does not have a security code programmed, then pressing the **I** key will do nothing.
4. To enter **Programming Mode**, press the key of a function to be changed. While in Programming Mode, the three colored LEDs on the left will change states depending on the function selected. To change the setting, push the key of the desired setting value.

TIPS:

- Once the security code is entered, the unit will remain unlocked for 60 seconds. This timer doesn't run while in **Programming Mode** and is reset to 60 seconds after hitting the **#** key.
- If the security code is unavailable, cycle power to the sensor. On power-up, no security key is needed for 60 seconds. Refer to the manual for instructions on resetting the security code.

TIP: **Function keys:** **A** thru **I**
Setting values: **1** thru **9**

The next page will cover a few of the functions/programmable parameters. See the manual for detailed explanations of all functions.

TIP: To read currently programmed settings, press the ***** key to enter into **Read Mode**. Next, press a function key, and then the **#** key. The green LED on the front of the sensor will flash 1-9 times, indicating the function setting.

5. **To save programmed settings, or leave Read Mode, press the **#** key.**

Change the setting of a function	Function → (1-9) → #
Enter Programming Mode with a security code	(I) → (1-9) (1-9) (1-9) (1-9) → #
Checking the current setting of a function	(*) → Function → #

Configuring the Sensitivity Parameters

- Enter **Programming Mode** by pressing a function key.
- Microwave Vehicle Motion Sensitivity** - Press the **(D)** key. Now press a number for the desired value (1 thru 9 are valid). Raising the value increases the detection area size, lowering it shrinks the area. Lower this setting if humans are being detected by the microwave vehicle motion sensor.
- Infrared Presence Sensitivity** - Press the **(E)** key. Now press a number for the desired setting value (1 thru 6). Raising this number will make the presence detection more sensitive to movement, lowering it will make it less sensitive.

Common Programmable Parameters

Configure Relays - Set relay behavior (Presence/Motion)					Default settings are in bold with a gray background				
(A)	(1) - NO/NO	(2) - NO/NC	(3) - NC/NO	(4) - NC/NC					
Presence Timer - Detection time before presence sensor relearns the local environment									
(↑) (B)	(1) 30s	(2) 1min	(3) 2min	(4) 5min	(5) 10min	(6) 20min	(7) 1hr	(8) 2h	(9) Never
IR Detection Target - Configure IR to detect people & vehicles, or vehicles only									
(↑) (F)	(1) - People & Vehicles				(2) - Vehicles only				

Infrared Array - The OWL uses a pair of 6 x 5 infrared LED arrays to detect the presence of vehicles & people. The array is highly customizable. The furthest rows can be turned off, decreasing the reach of the presence detection area. The columns can be turned off in pairs, decreasing the width of the presence detection area.

	(1)	(2)	(3)	(4)	(5)
IR Rows - Adjusts which IR LED rows are on					
(F)	1 row	2 rows	3 rows	4 rows	All rows
IR Columns, Left Side - Adjusts which left-side IR columns are on					
(G)	None	2 columns	4 columns	All columns	
IR Columns, Right Side - Adjusts which right-side IR columns are on					
(H)	None	2 columns	4 columns	All columns	

To the right is a top-down example of an OWL installation, demonstrating how turning off columns and rows affects the invisible presence detection area on the ground.

= Off
 = On

